

THERMASGARD® TH 08

Immersion sleeves made of stainless steel or brass, nickel-plated /galvanised, for temperature sensors and measuring transducers

TF 43, TM 43, TF 65, TM 65, TM 65-Modbus (Tyr 1)]



S+S REGELTECHNIK

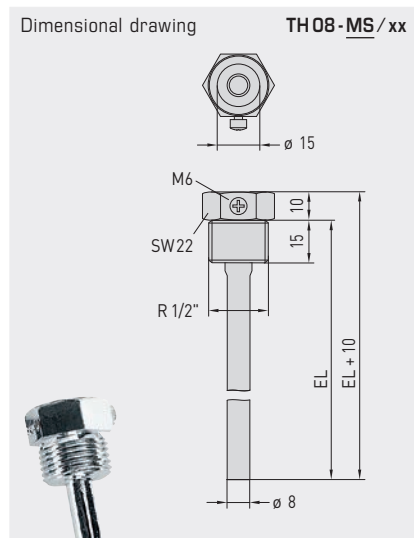

TH08-MS/xx

Immersion sleeve, nickel-plated brass / galvanised

thread-sealing, conical, according to DIN 10226

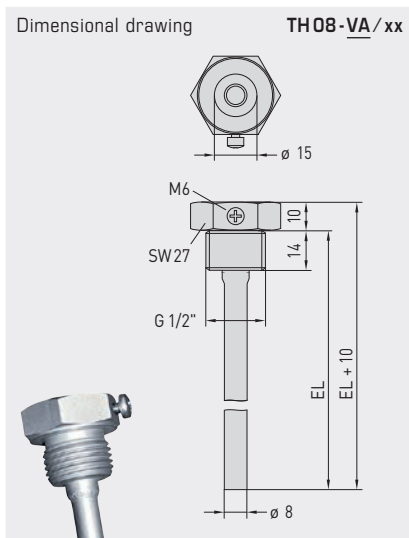

TH08-VA/xx

Immersion sleeve, stainless steel V4A (1.4571)

flat sealing, cylindrical, according to DIN 228

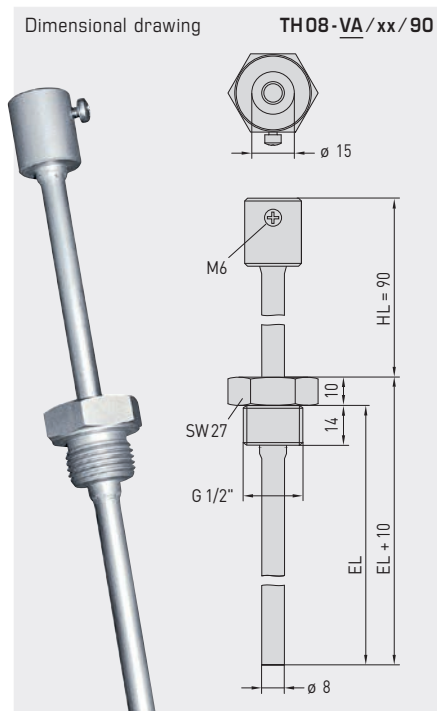

TH08-VA/xx/90

Immersion sleeve, stainless steel V4A (1.4571) with neck tube

flat sealing, cylindrical, according to DIN 228



THERMASGARD® TH 08 Immersion sleeve Ø 8 mm					
Type / WGD1	p _{max} (static)	T _{max}	Inserted length (EL)	Item No.	Price
TH08-MS/xx	Brass nickel-plated / galvanised			Ø 8 x 0.75 mm	
TH08-MS 50MM	10 bar	+150 °C	50 mm	7100-0011-0010-132	13,42 €
TH08-MS 100MM	10 bar	+150 °C	100 mm	7100-0011-0020-132	14,04 €
TH08-MS 150MM	10 bar	+150 °C	150 mm	7100-0011-0030-132	15,18 €
TH08-MS 200MM	10 bar	+150 °C	200 mm	7100-0011-0040-132	16,24 €
TH08-MS 250MM	10 bar	+150 °C	250 mm	7100-0011-0050-132	18,81 €
TH08-MS 300MM	10 bar	+150 °C	300 mm	7100-0011-0060-132	19,66 €
TH08-MS 350MM	10 bar	+150 °C	350 mm	7100-0011-0070-132	20,18 €
TH08-MS 400MM	10 bar	+150 °C	400 mm	7100-0011-0080-132	20,70 €
TH08-VA/xx	Stainless steel V4A (1.4571)			Ø 8 x 0.75 mm	
TH08-VA 50MM	40 bar	+600 °C	50 mm	7100-0012-0010-132	23,13 €
TH08-VA 100MM	40 bar	+600 °C	100 mm	7100-0012-0020-132	25,48 €
TH08-VA 150MM	40 bar	+600 °C	150 mm	7100-0012-0030-132	27,56 €
TH08-VA 200MM	40 bar	+600 °C	200 mm	7100-0012-0040-132	28,91 €
TH08-VA 250MM	40 bar	+600 °C	250 mm	7100-0012-0050-132	35,98 €
TH08-VA 300MM	40 bar	+600 °C	300 mm	7100-0012-0060-132	37,65 €
TH08-VA 350MM	40 bar	+600 °C	350 mm	7100-0012-0070-132	38,38 €
TH08-VA 400MM	40 bar	+600 °C	400 mm	7100-0012-0080-132	39,42 €
TH08-VA/xx/90	Stainless steel V4A (1.4571), with neck tube (90mm)			Ø 8 x 0.75 mm	
TH08-VA 50/90MM	40 bar	+600 °C	50 mm	7100-0012-0012-132	31,11 €
TH08-VA 100/90MM	40 bar	+600 °C	100 mm	7100-0012-0022-132	32,51 €
TH08-VA 150/90MM	40 bar	+600 °C	150 mm	7100-0012-0032-132	34,11 €
TH08-VA 200/90MM	40 bar	+600 °C	200 mm	7100-0012-0042-132	35,56 €
TH08-VA 250/90MM	40 bar	+600 °C	250 mm	7100-0012-0052-132	37,26 €
TH08-VA 300/90MM	40 bar	+600 °C	300 mm	7100-0012-0062-132	40,39 €

Note: Inner diameter of socket 15.0 mm



Immersion sleeves made of stainless steel or brass, nickel-plated /galvanised, for temperature sensors and measuring transducers TF 43, TM 43, TF 65, TM 65, TM 65-Modbus (Tyr 1)

INSTRUCTIONS FOR PLANNING AND INSTALLATION

The approaching flow causes the protective tube to vibrate.

If the specified approach velocity is exceeded even by a marginal amount, a negative impact on the protective tube's service life may result (material fatigue).

Please observe permissible approach velocities for stainless steel protective tubes (see graph TH08-VA) as well as for brass protective tubes (see graph TH08-MS).

Discharge of gases and pressure surges must be avoided as they have a negative influence on the service life and may damage the protective tubes irreparably.

MIXING SECTION

After the mixing of water flows of different temperatures, the issue of temperature stratification means that an adequate distance to the sensor must be observed.

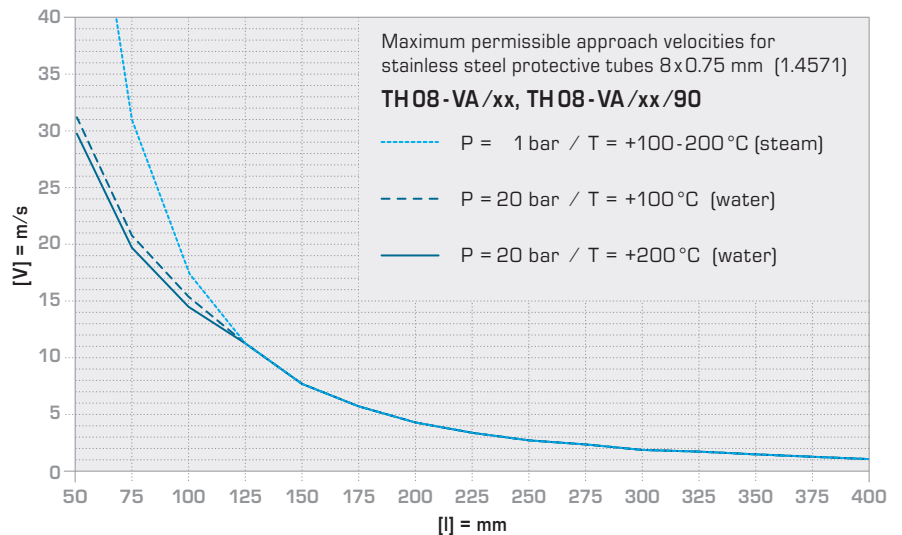
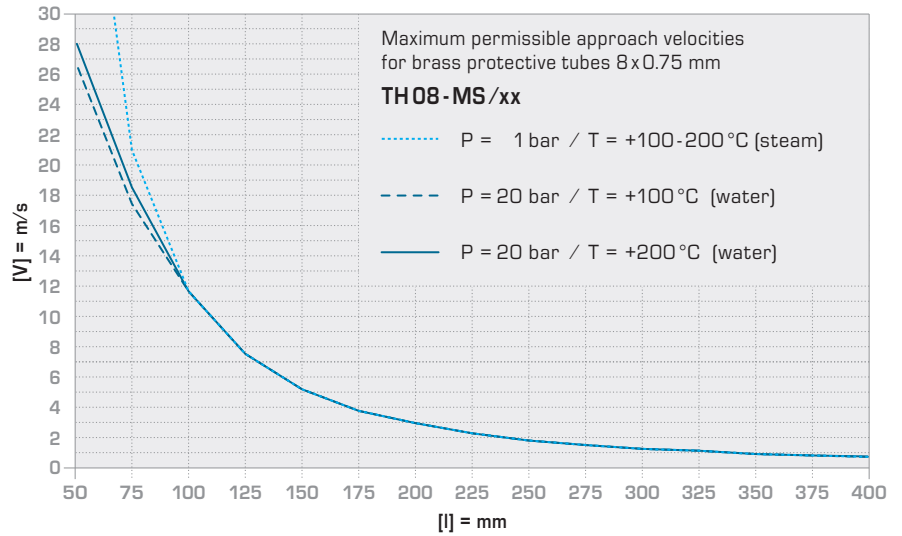
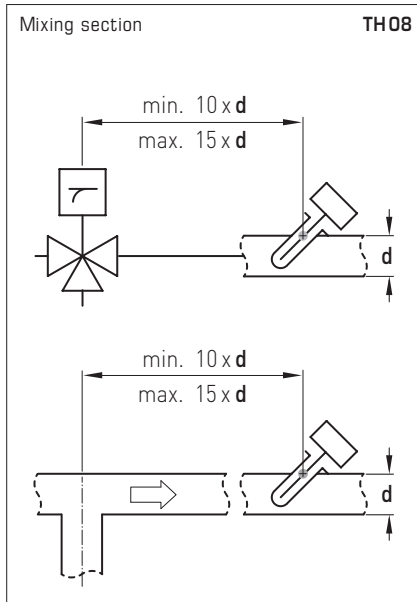

When Copper and Zinc are Not Enough

Uncompromising quality and safety are also paramount in the design of the accessory from S+S. This is why our metal immersion sleeves for duct sensors are made using either nickel plated brass or stainless steel.

In contrast to conventional products in the market, however, our brass immersion sleeves feature an additional nickel coating. This ensures their longterm corrosion resistance in minor aggressive media, from air and water to alkaline solutions and diluted acids.

Highest protection against corrosion is provided by immersion sleeves made of stainless steel. Among the available qualities, we chose VA 1.4571 or AISI 316 Ti, a high-grade austenite specialty combining chromium, nickel and molybdenum with an extra titanium content.

