

THERMASGARD® RPTM 1-Modbus-T3

THERMASGARD® RPTM 1-wModbus



S+S REGELTECHNIK

Pendulum room temperature measuring transducer,
(with stainless steel sleeve), calibratable,
with Modbus connection or W-Modbus (wireless)

Calibratable room pendulum temperature measuring transducer (with sleeve) **THERMASGARD® RPTM 1-Modbus-T3**, with Modbus connection, in an impact-resistant plastic housing with quick-locking screws, cable sensor with stainless steel sleeve and plastic sinter filter (exchangeable), optionally with/without display, measures temperature (-50...+150 °C). International system of units **SI** (default) can be changed to **imperial** (via Modbus). With **wModbus** device version, the W-Modbus (Wireless) replaces the RTU cable; the BMS connection is radio-based using a W-Modbus gateway.

The pendulum sensor has been specially designed to detect the temperature in larger rooms or halls. The resistance thermometer achieves a very good representative measurement result due to its positioning in the room.

Innovative Modbus sensor with galvanically isolated RS485 Modbus interface, switchable bus terminating resistor, DIP switch for setting in current-free state, internal LEDs for telegram status display, push-in terminals and large three-line display (illuminated, individually programmable). Uses **internal diagnostics** to detect sensor breakage or sensor short circuit as errors. The sensor is factory-calibrated; an environmental precision adjustment by an expert is possible.

RPTM 1-Modbus-T3
without display
(RTU cable)



RPTM 1-wModbus
without display
(wireless)



Programmable display screen
Tyr 3



TECHNICAL DATA

Power supply:	24 V AC (±20%); 15...36 V DC
Power consumption:	< 1.2 W / 24 V DC; < 1.8 VA / 24 V AC
System of units:	SI (default) or Imperial (switchable via Modbus)
Data points:	temperature [°C] [°F]
Sensor:	Pt1000, DIN EN 60751, class B
Measuring range:	-50...+150 °C
Accuracy, temperature:	typically ±0.2 K at +25 °C
Zero point offset:	±10 °C
Ambient temperature:	measuring transducer -30...+70 °C
Medium:	clean air and non-aggressive, non-combustible gases
Communication:	Modbus (RTU cable), Bus interface RS 485, galvanically isolated , Baud rate 9600, 19200, 38400 baud or W-Modbus (Wireless Modbus, AES-128 encrypted) Frequency 2.4 GHz ISM, Transmission power 100 mW , Range max. 500 m (open field) / approx. 50 - 70 m (inside buildings)
Bus protocol:	Modbus (RTU mode), address range 0... 247 adjustable
Signal filtering:	0,3 s / 1 s / 10 s
Sensor protection:	plastic sinter filter, Ø 16 mm, L = 35 mm, exchangeable (optional metal sinter filter, Ø 16 mm, L = 32 mm)
Protective tube:	stainless steel V2A (1.4301), Ø=16 mm, NL = 142 mm
Sensor cable:	PVC, H03VV-F, 2 x 0.5 mm ² , cable length (KL) = approx. 1.5 m (other lengths optional)
Housing:	plastic, UV-resistant, material polyamide, 30 % glass-globe reinforced, with quick-locking screws (slotted / Phillips head combination), colour traffic white (similar to RAL 9016), housing cover for display is transparent!
Housing dimensions:	108 x 78.5 x 43.3 mm (Tyr 3 without display) 108 x 78.5 x 45,8 mm (Tyr 3 with display)
Cable connection:	cable gland , plastic (M20 x 1.5; with strain relief, exchangeable, inner diameter 8 - 13 mm) or M12 connector according to DIN EN 61076-2-101 (optional on request)
Electrical connection:	0.2 - 1.5 mm ² , using push-in terminals
Permissible air humidity:	<95 % RH, non-precipitating air
Protection class:	III (according to EN 60 730)
Protection type:	IP 65 (according to EN 60 529)
Standards (Modbus):	CE conformity according to EMC Directive 2014 / 30 / EU
Standards (W-Modbus):	CE conformity according to Radio Directive 2014 / 53 / EU
Features:	display with illumination , three-line, programmable, cutout approx. 51 x 29 mm (W x H), for displaying the actual temperature, error message or an individually programmable display value
Internal diagnostics:	Error 1 at sensor breakage Error 2 at sensor short circuit



NEW

S+S REGELTECHNIK

THERMASGARD® RPTM1-Modbus-T3 THERMASGARD® RPTM1-wModbus

Pendulum room temperature measuring transducer,
(with stainless steel sleeve), calibratable,
with Modbus connection or W-Modbus (wireless)

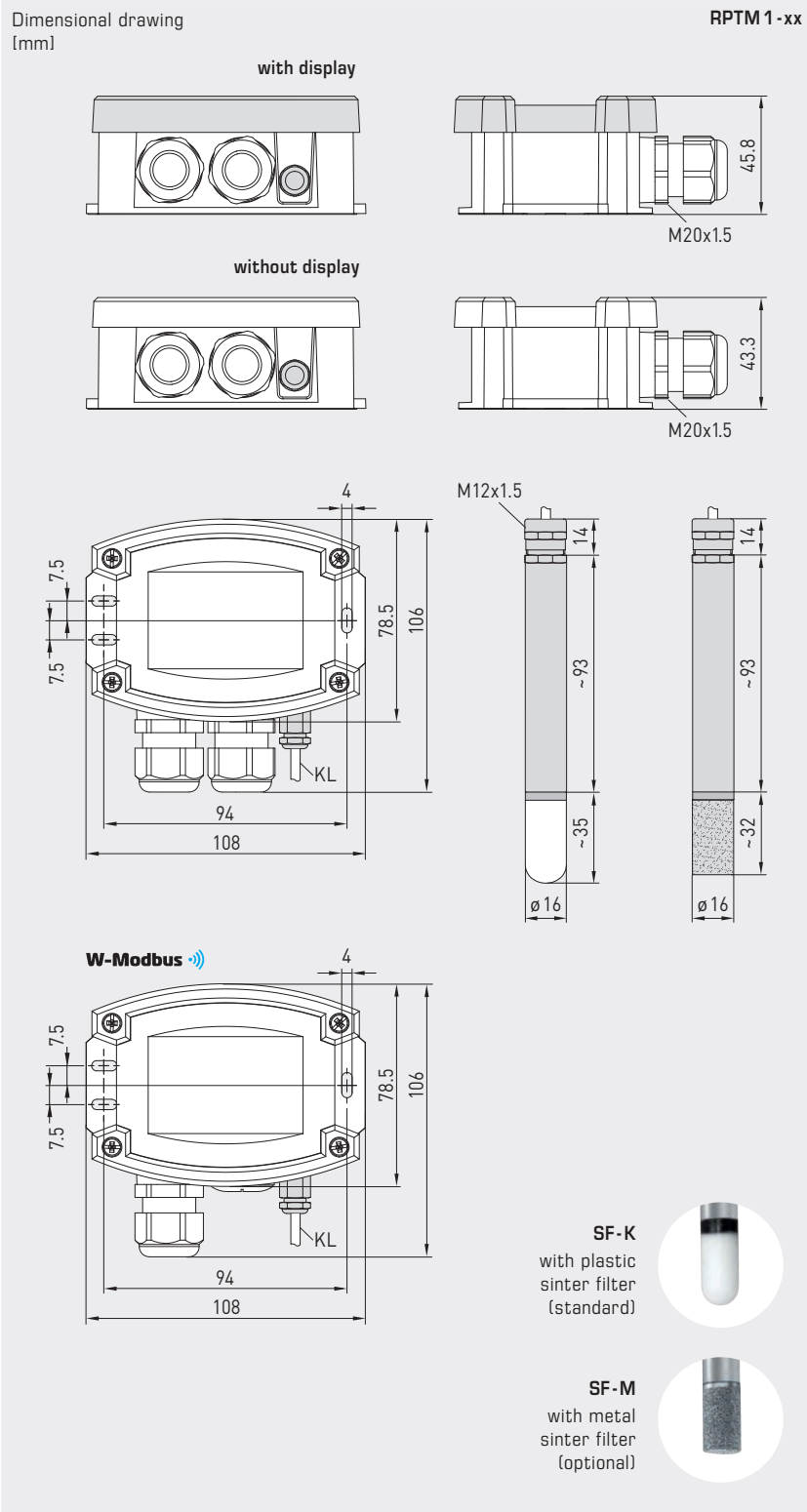

Device version with **M12 connector** (optional on request)



MF-16-K
Mounting flange, plastic (optional)



RPTM1-Modbus-T3
with display
(RTU cable)



RPTM1-wModbus
with display
(wireless)



THERMASGARD® RPTM1-Modbus-T3

THERMASGARD® RPTM1-wModbus



S+S REGELTECHNIK

Pendulum room temperature measuring transducer,
(with stainless steel sleeve), calibratable,
with Modbus connection or W-Modbus (wireless)

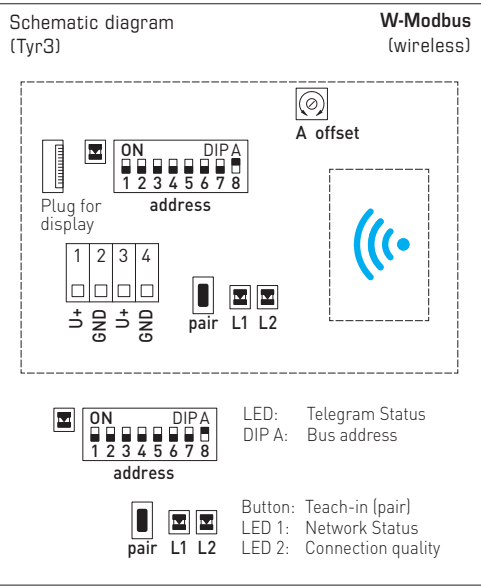
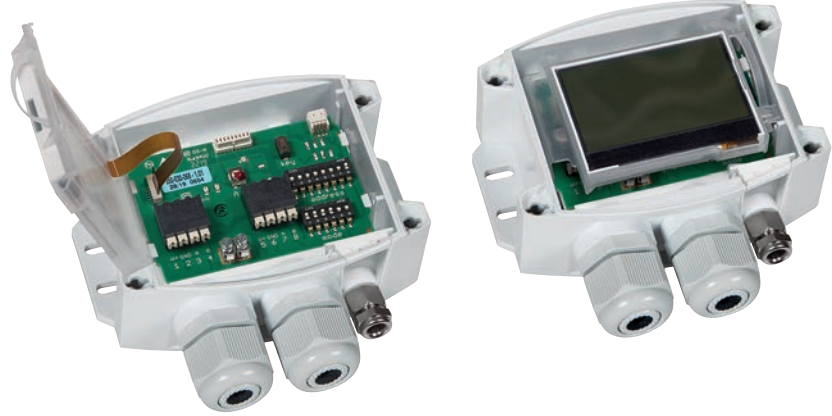
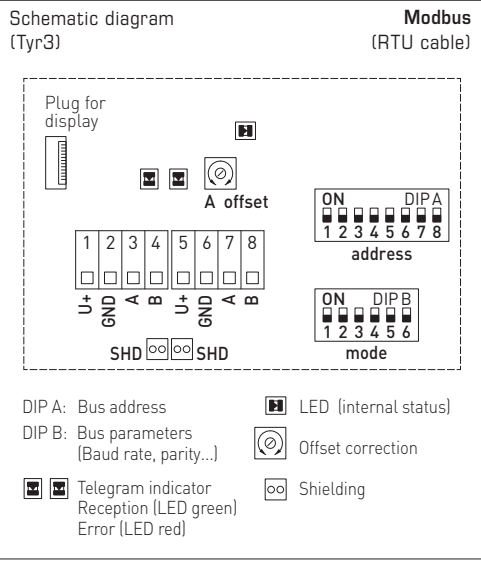

GW-wModbus (Pro)
Gateway with W-Modbus module,
for radio-based connection to Modbus networks





NEW

S+S REGELTECHNIK

THERMASGARD® RPTM1-Modbus-T3 THERMASGARD® RPTM1-wModbus

Pendulum room temperature measuring transducer,
(with stainless steel sleeve), calibratable,
with Modbus connection or W-Modbus (wireless)

RPTM1-wModbus
with / without display
(wireless)



RPTM1-Modbus-T3
with / without display
(RTU cable)



THERMASGARD® RPTM1-Modbus-T3 RPTM1-wModbus Pendulum room temperature measuring transducer (with stainless steel sleeve) with Modbus connection (RTU cable) or with W-Modbus (wireless)



Type / WG01	Output	Type	Display	Item No.	Price
RPTM1-xx					
RPTM1-Modbus-T3	Modbus (RTU cable)	Remote sensor		1101-6286-0210-000	229,94 €
RPTM1-Modbus-T3 LCD	Modbus (RTU cable)	Remote sensor	■	1101-6286-4210-000	288,61 €
RPTM1-wModbus	W-Modbus (wireless)	Remote sensor		1101-628F-0210-000	271,54 €
RPTM1-wModbus LCD	W-Modbus (wireless)	Remote sensor	■	1101-628F-4210-000	330,21 €
Extra charge:	per running metre of connecting lead (PVC)			on request	
	Cable connection with M12 connector according to DIN EN 61076-2-101			on request	
Note:	System of units SI (default) or imperial (can be changed via Modbus).				

MODBUS ACCESSORIES

GW-wModbus	Gateway with W-Modbus (Wireless) for radio-based connection to Modbus networks, operating modes 'Gateway' (basic function as a base station) and 'Node' (adapter function for max. 1 wired sensor)	1801-1211-1101-000	238,16 €
GW-wModbus Pro	and 'Node Pro' (adapter function for max. 16 wired sensors)	1801-1211-1101-100	322,40 €
KA2-Modbus	Communication adapter (USB/RS485) for system connection	1906-1200-0000-100	229,23 €
LA-Modbus	Line termination device (with terminating resistor) as an active bus termination	1906-1300-0000-100	85,49 €
For further information see the end of the chapter!			

ACCESSORIES

SF-M	Metal sinter filter , Ø 16 mm, L = 32 mm, exchangeable stainless steel V4A (1.4404)	7000-0050-2200-100	45,34 €
MF-16-K	Mounting flange plastic (optional)	7100-0030-0000-000	10,24 €
For further information, see last chapter Accessories!			