

THERMASGARD® MWTM-Modbus-T3

THERMASGARD® MWTM-wModbus



S+S REGELTECHNIK

Mean value temperature measuring transducers,
incl. mounting flange, calibratable,
with Modbus connection or W-Modbus (wireless)

Calibratable mean value temperature measuring transducer **THERMASGARD® MWTM-Modbus-T3**, with Modbus connection, in an impact-resistant plastic housing with quick-locking screws, with flexible sensor rod (0.4...20m, fully active) in a robust protective plastic-coated copper tube, incl. mounting flange, optionally with /without display, measures temperature (-50...+150 °C). International system of units **SI** (default) can be changed to **imperial** (via Modbus). With **wModbus** device version, the W-Modbus (Wireless) replaces the RTU cable; the BMS connection is radio-based using a W-Modbus gateway.

The rod sensor is used to detect the mean temperature (mean value) in gaseous media. It is used in ventilation and air conditioning ducts over the entire cross-section or on a defined length (laid along a meandering route, it uniformly detects the surrounding temperature). For proper mounting of the rod, mounting clamps **MK-05-M** (accessories) are available.

Innovative Modbus sensor with galvanically isolated RS485 Modbus interface, switchable bus terminating resistor, DIP switch for setting in current-free state, internal LEDs for telegram status display, push-in terminals and large three-line display (illuminated, individually programmable). Uses **internal diagnostics** to detect sensor breakage or sensor short circuit as errors. The sensor is factory-calibrated; an environmental precision adjustment by an expert is possible.

MWTM-Modbus-T3
without display
(RTU cable)



TECHNICAL DATA

Power supply:	24 V AC (± 20%); 15...36 V DC
Power consumption:	< 1.2 W / 24 V DC; < 1.8 VA / 24 V AC
System of units:	SI (default) or Imperial (switchable via Modbus)
Data points:	temperature [°C] [°F]
Sensor:	Pt1000, DIN EN 60751, class B
Measuring range:	-50...+150 °C; T_{min} -50 °C, T_{max} +80 °C
Accuracy, temperature:	typically ± 0.2 K at +25 °C
Zero point offset:	± 10 °C
Ambient temperature:	measuring transducer -30...+70 °C
Medium:	clean air and non-aggressive, non-combustible gases
Communication:	Modbus (RTU cable), Bus interface RS 485, galvanically isolated , Baud rate 9600, 19200, 38400 baud or W-Modbus (Wireless Modbus, AES-128 encrypted) Frequency 2.4 GHz ISM, Transmission power 100 mW , Range max. 500 m (open field) / approx. 50-70 m (inside buildings)
Bus protocol:	Modbus (RTU mode), address range 0... 247 adjustable
Signal filtering:	0.3 s / 1 s / 10 s
Sensor:	active across the entire length (averaging)
Rod material:	protective tube made from copper, plastic-coated , with anti-kink spring and sleeve, stainless steel V4A (1.4571)
Rod dimensions:	Ø = 5.0 mm, nominal length (NL) = 0.4 m / 3 m / 6 m (nominal length optional up to max. 20 m)
Rod laying:	Bending radius: > 35 mm Vibration load: ≤ 0.5 g Tensile load: < 480 N
Housing:	plastic, UV-resistant, material polyamide, 30% glass-globe reinforced, with quick-locking screws (slotted / Phillips head combination), colour traffic white (similar to RAL 9016), housing cover for display is transparent!
Housing dimensions:	108 x 78.5 x 43.3 mm (Tyr 3 without display) 108 x 78.5 x 45.8 mm (Tyr 3 with display)
Cable connection:	cable gland , plastic (M20 x 1.5; with strain relief, exchangeable, inner diameter 8 - 13 mm) or M12 connector according to DIN EN 61076-2-101 (optional on request)
Electrical connection:	0.2 - 1.5 mm², using push-in terminals
Process connection:	by mounting flange, plastic (galvanised steel optional, see accessories) and mounting clamps MK-05-M
Permissible air humidity:	< 95 % RH, non-precipitating air
Protection class:	III (according to EN 60 730)
Protection type:	IP 65 (according to EN 60 529)
Standards (Modbus):	CE conformity according to EMC Directive 2014 / 30 / EU
Standards (W-Modbus):	CE conformity according to Radio Directive 2014 / 53 / EU
Features:	display with illumination , three-line, programmable, cutout approx. 51 x 29 mm (W x H), for displaying the actual temperature, error message or an individually programmable display value
Internal diagnostics:	Error 1 at sensor breakage Error 2 at sensor short circuit

MWTM-wModbus
without display
(wireless)



Programmable display screen **Tyr 3**





NEW

S+S REGELTECHNIK

THERMASGARD® MWTM-Modbus-T3 THERMASGARD® MWTM-wModbus

Mean value temperature measuring transducers,
incl. mounting flange, calibratable,
with Modbus connection or W-Modbus (wireless)

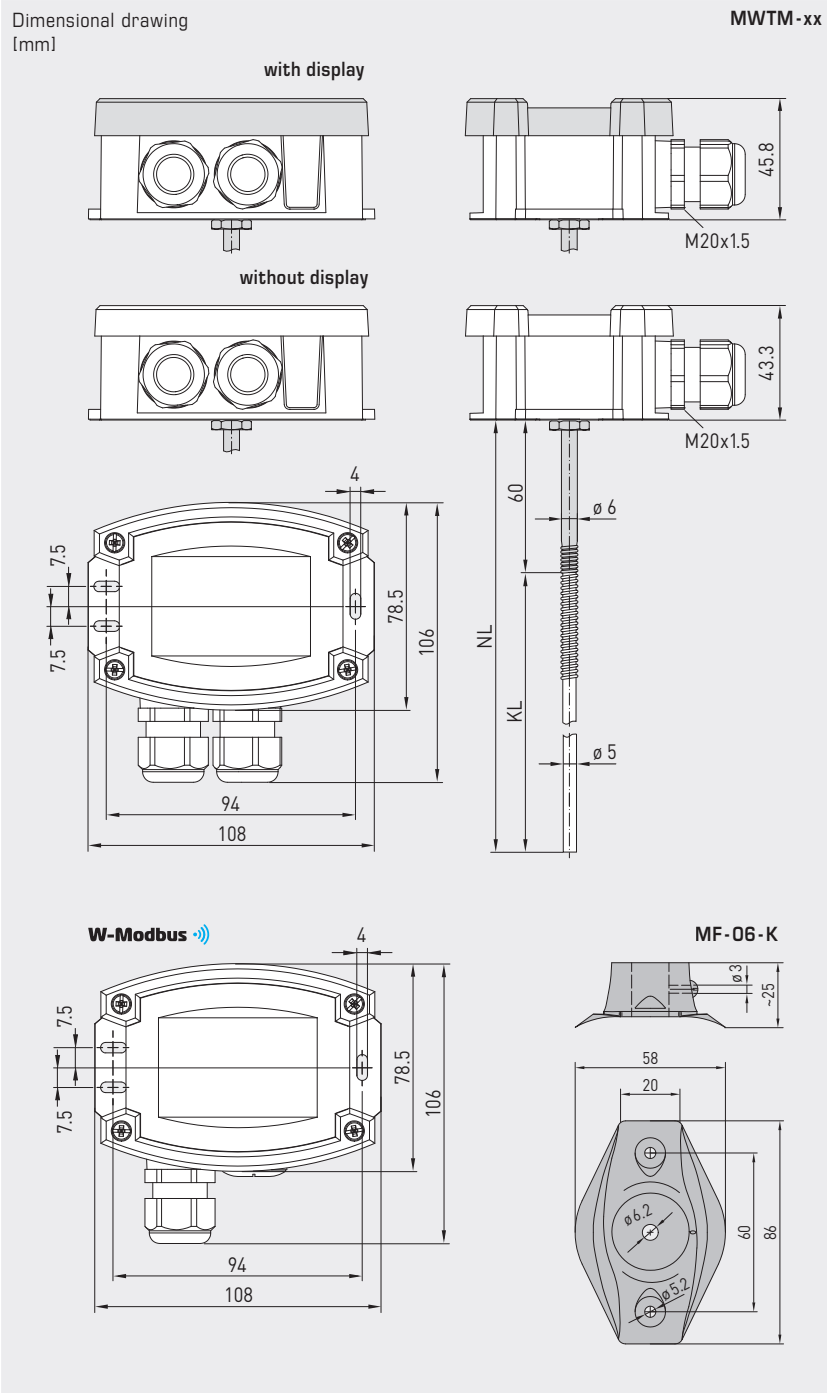

MWTM-Modbus-T3
with display
(RTU cable)



MWTM-wModbus
with display
(wireless)



MF-06-M

Mounting flange,
metal
(optional)



KRD-04

Capillary tube
gland bracket,
plastic
(optional)



MF-06-K

Mounting flange,
plastic
(included in the
scope of delivery)



Device version
with **M12 connector**
(optional on request)



THERMASGARD® MWTM-Modbus-T3

THERMASGARD® MWTM-wModbus



S+S REGELTECHNIK

Mean value temperature measuring transducers,
incl. mounting flange, calibratable,
with Modbus connection or W-Modbus (wireless)

Schematic diagram (Tyr3) Modbus (RTU cable)

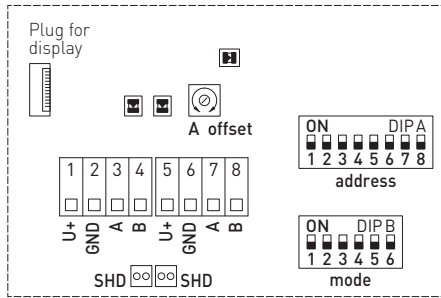

- DIP A: Bus address
- DIP B: Bus parameters (Baud rate, parity...)
- Telegram indicator Reception (LED green) Error (LED red)
- LED (internal status)
- Offset correction
- Shielding

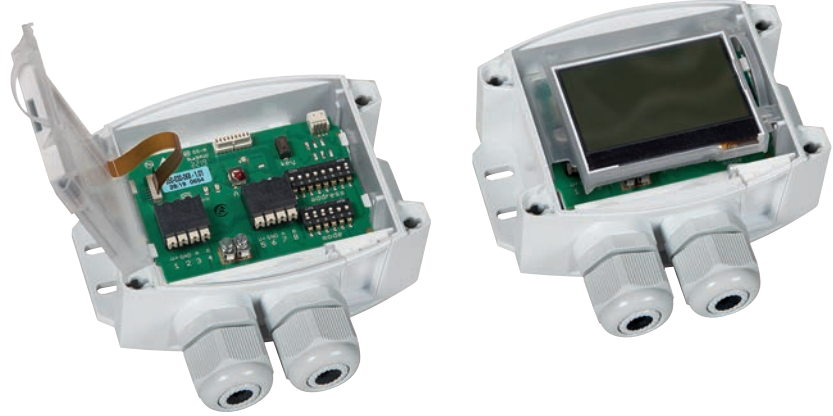

Schematic diagram (Tyr3) W-Modbus (wireless)

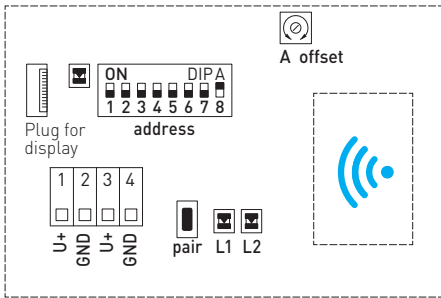

- LED: Telegram Status
- DIP A: Bus address
- pair L1 L2
- Button: Teach-in (pair)
- LED 1: Network Status
- LED 2: Connection quality



Dimensional drawing MF-06-K

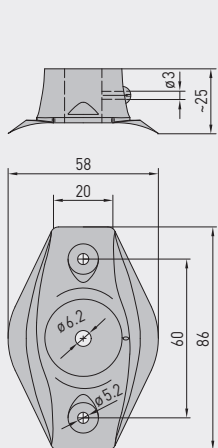

Dimensional drawing KRD-04

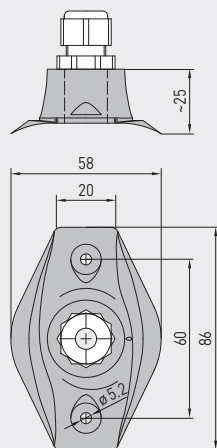

Dimensional drawing MF-06-M

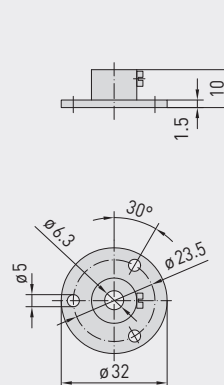

Dimensional drawing MK-05-M

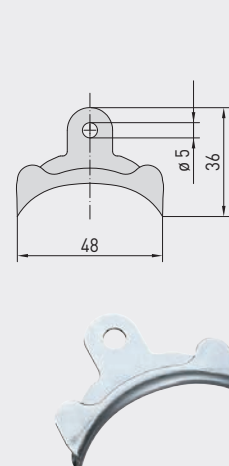



NEW

S+S REGELTECHNIK

THERMASGARD® MWTM - Modbus - T3 THERMASGARD® MWTM - wModbus

Mean value temperature measuring transducers,
incl. mounting flange, calibratable,
with Modbus connection or W-Modbus (wireless)

MWTM - wModbus
with / without display
(wireless)



MWTM - Modbus - T3
with / without display
(RTU cable)



THERMASGARD® Mean value temperature measuring transducers, with Modbus connection (RTU cable) or with W-Modbus (wireless)



Type / WG01	Output	Rod length (NL)	Display	Item No.	Price
MWTM - Modbus - T3					
MWTM-Modbus_T3 0,4m	Modbus (RTU cable)	0.4 m		1101-3266-0080-000	257,46 €
MWTM-Modbus-T3 0,4m LCD	Modbus (RTU cable)	0.4 m	■	1101-3266-4080-000	315,05 €
MWTM-Modbus-T3 3m	Modbus (RTU cable)	3.0 m		1101-3266-0230-000	314,20 €
MWTM-Modbus-T3 3m LCD	Modbus (RTU cable)	3.0 m	■	1101-3266-4230-000	372,36 €
MWTM-Modbus-T3 6m	Modbus (RTU cable)	6.0 m		1101-3266-0260-000	354,94 €
MWTM-Modbus-T3 6m LCD	Modbus (RTU cable)	6.0 m	■	1101-3266-4260-000	413,46 €
MWTM - wModbus					
MWTM-wModbus 0,4M	W-Modbus (wireless)	0.4 m		1101-326F-0080-000	299,06 €
MWTM-wModbus 0,4M LCD	W-Modbus (wireless)	0.4 m	■	1101-326F-4080-000	356,65 €
MWTM-wModbus 3M	W-Modbus (wireless)	3.0 m		1101-326F-0230-000	355,80 €
MWTM-wModbus 3M LCD	W-Modbus (wireless)	3.0 m	■	1101-326F-4230-000	413,96 €
MWTM-wModbus 6M	W-Modbus (wireless)	6.0 m		1101-326F-0260-000	396,54 €
MWTM-wModbus 6M LCD	W-Modbus (wireless)	6.0 m	■	1101-326F-4260-000	455,06 €

Extra charge: per meter sensor cable (from 6 m to max. 20 m) on request
cable connection with **M12 connector** according to DIN EN 61076-2-101 on request

Note: System of units **SI** (default) or **imperial** (can be changed via Modbus).

MODBUS ACCESSORIES

GW-wModbus	Gateway with W-Modbus (Wireless) for radio-based connection to Modbus networks, operating modes 'Gateway' (basic function as a base station) and 'Node' (adapter function for max. 1 wired sensor)	1801-1211-1101-000	238,16 €
GW-wModbus Pro	and 'Node Pro' (adapter function for max. 16 wired sensors)	1801-1211-1101-100	322,40 €
KA2-Modbus	Communication adapter (USB/RS485) for system connection	1906-1200-0000-100	229,23 €
LA-Modbus	Line termination device (with terminating resistor) as an active bus termination	1906-1300-0000-100	85,49 €

For further information see the end of the chapter!

ACCESSORIES

MF-06-K	Mounting flange, plastic (included in the scope of delivery)	7100-0030-1000-000	6,55 €
MF-06-M	Mounting flange, metal, galvanised steel, Ø = 32 mm	7100-0030-5000-100	13,47 €
KRD-04	Capillary tube gland bracket, plastic	7100-0030-7000-000	9,55 €
MK-05-M	Galvanised steel mounting clamps (6 pieces)	7100-0034-0000-000	10,59 €

For further information, see last chapter Accessories!