

Room light intensity sensor and measuring transducer, in-wall in the panel switch programme, with active output

Maintenance-free light intensity sensor **PHOTASGARD® FSHKM** with active output, in in-wall housing, to determine the illuminance (0...1kLux). The measuring transducer converts the measured variables into a standard signal of 0-10V. The in-wall sensor is mounted in high-quality panel switch programmes, ideally of the brands Gira, Berker, Merten, Jung, Siemens or Busch-Jaeger (using in-wall adapters) either individually or in combination with light switches, socket outlets, etc.

The sensor is used to control luminaires, lighting systems, Venetian blinds and canvas blinds and for monitoring the lighting conditions. It is used indoors at workplaces, in corridors, offices, residential and business premises as well as industrial and storage halls as daylight-dependent constant light control, as brightness or twilight sensor and to control sun protection hoods to avoid unnecessary room heating.

The **light sensor (photodiode)** was specifically adapted to the sensitivity of the human eye. It is most sensitive in the range of 350 nm to 820 nm. With its special filter, the sensor is therefore ideally suited to exposure measurement of daylight and/or for measuring artificial light of high colour temperature (similar to sunlight).

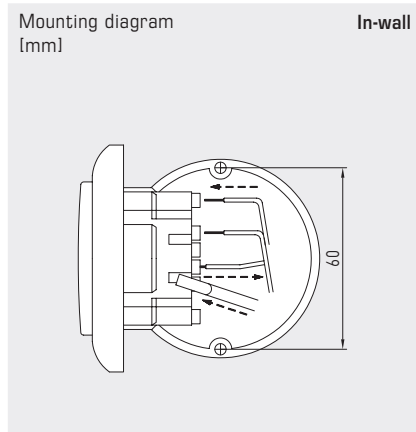

TECHNICAL DATA

Power supply:	24 V AC / DC (± 10 %)
Power consumption:	typically < 2.0 VA / 24 V AC; typically < 1.0 W / 24 V DC

BRIGHTNESS

Sensor:	Light sensor (photo diode)
Measuring range:	0...1 kLux (optionally other individual measuring ranges, e. g. 100 kLux)
Accuracy:	typically ± 10 % final value
Output:	0 - 10 V (linearised)
Mounting:	in-wall flush box Ø 55 mm
Electrical connection:	max. 1.5 mm², via push-in terminals
Ambient temperature:	Storage -20...+50 °C; Operation 0...+50 °C
Permitted humidity:	max. 95 % RH, non-condensing air
Protection class:	III (according to EN 60 730)
Protection type:	IP 20 (according to EN 60 529)
Standards:	CE-conformity according to EMC Directive 2014 / 30 / EU

SWITCH PROGRAMME

Manufacturer:	GIRA System 55 (other switch programmes, manufacturers, colours as well as prices available upon request)
Housing:	plastic, the standard colour is pure glossy white (similar to RAL 9010) (other colours are available upon request with colour variants depending on the respective light switch programme)

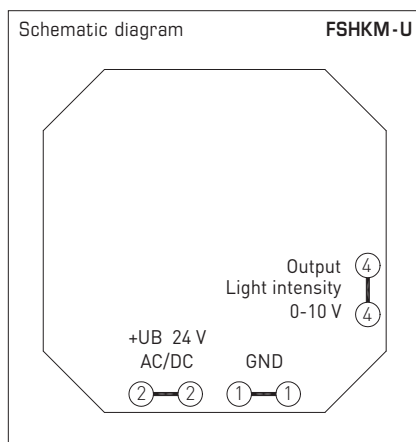



S+S REGELTECHNIK

Room light intensity sensor and measuring transducer,
in-wall in the panel switch programme,
with active output

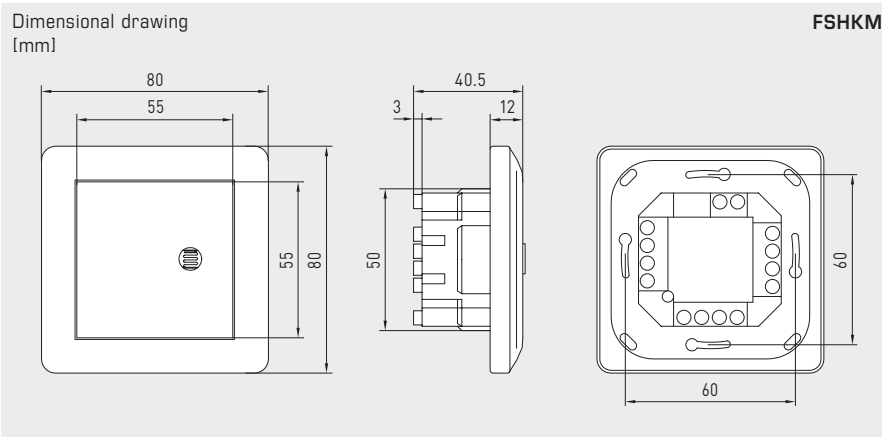

FSHKM



Light Intensity table
MB: 0...1000 lux

Light [lux]	U _A [V]
0	0.0
50	0.5
100	1.0
150	1.5
200	2.0
250	2.5
300	3.0
350	3.5
400	4.0
450	4.5
500	5.0
550	5.5
600	6.0
650	6.5
700	7.0
750	7.5
800	8.0
850	8.5
900	9.0
950	9.5
1000	10.0

PHOTASGARD® FSHKM		Room light intensity sensor or measuring transducer, in-wall		
Type / WG02	Measuring range Light Intensity	Output Light Intensity	Item No.	Price
FSHKM				
FSHKM-U 1K	0...1 kLux	0-10 V	1601-5121-7000-162	263,19 €
Extra charge:	optionally other individual measuring ranges, e. g. 100 kLux		on request	

