

**Outside temperature / wet room temperature measuring transducers,  
calibratable, with multi-range switching and  
active output (Automatic Output Switching)**

**Patented quality product** (patent no. DE 10 2015 015 941 B4)

Calibratable outside temperature measuring transducer **THERMASGARD® ATM 2 - VA**, with eight switchable measuring ranges (max. -20...+150 °C), active output, external sensor, rugged housing made from **stainless steel V4A**, with cable gland or M12 connector according to DIN EN 61076-2-101.

The measuring transducer converts the measured variables into a standard signal of 0 - 10 V or 4...20 mA. The unit with **Automatic Output Switching** (AOS variant) detects the required output type and automatically switches to U or I output. Alternatively, a **type version** (2-wire I variant) with 2-wire connection and I output is available.

It is used to detect outside temperatures, temperatures in wet rooms, e.g. for installation on outside walls, in cold storage buildings and greenhouses, in the industrial sector and in agriculture. Installation in outdoor areas preferably at the north side of a building or in a protected place. In case of direct solar irradiation, we recommend using our sun and ball-impact protection hood **WS01** or **WS03** (accessories). The sensor is factory-calibrated; an environmental precision adjustment by an expert is possible.

## TECHNICAL DATA

### ATM2 - I

Power supply:	15...36 V DC, depending on working resistance, residual ripple stabilised ± 0.3 V
Working resistance:	$R_a \text{ (Ohm)} = (U_b - 14 \text{ V}) / 0.02 \text{ A}$
Connection type:	2-wire connection
Output:	<b>4...20 mA</b>

### ATM2 - A (AOS)

Power supply:	24 V AC / DC (± 10 %)
Load resistance:	$R_L = 25...450 \text{ Ohm}$ with AOS I variant $R_L > 15 \text{ kOhm}$ with AOS U variant
Connection type:	3-wire connection
Output:	<b>automatic 0-10 V / 4...20 mA</b> (via <b>Automatic Output Switching</b> – the unit detects the required output type and automatically switches to U or I output)

### GENERAL

Power consumption:	< 1.0 VA / 24 V DC; < 2.2 VA / 24 V AC
Measuring ranges:	<b>multi-range switching with 8 measuring ranges,</b> see table (other ranges optional) <b>with manual zero point correction (± 10 K)</b>
Sensor:	Pt1000, DIN EN 60751, class B <b>(Perfect Sensor Protection)</b>
Accuracy, temperature:	typically ± 0.2 K at +25 °C
Protective tube:	made from stainless steel <b>V4A</b> (1.4571), Ø 6 mm, NL = 65 mm
Housing:	<b>stainless steel V4A</b> (1.4571), with non-distortion cover bolting, impact resistant, high EMI shielding, corrosion, temperature, weather- and UV-resistant
Housing dimension:	143 x 97 x 61 mm (Tyr2E)
Cable connection:	<b>cable gland, stainless steel V2A</b> (1.4305) (M20 x 1.5; with strain relief, exchangeable, inner diameter 6 - 12 mm) <b>or</b> <b>M12 connector</b> (male, 5-pin, A-code) according to DIN EN 61076-2-101
Electrical connection:	0.14 - 1.5 mm <sup>2</sup> , via terminal screws
Process connection:	by means of screws
Ambient temperature:	measuring transducer -30...+70 °C
Permissible humidity:	< 95 % RH, non-precipitating air
Protection class:	III (according EN 60 730)
Protection type:	<b>IP65</b> (according to EN 60 529) Housing tested, TÜV SÜD, Report No. 713160960B (Skadi2)
Standards:	CE conformity according to EMC directive 2014 / 30 / EU

**ACCESSORIES** (see table)



**NEW**

S+S REGELTECHNIK

THERMASGARD® ATM 2 - VA

Outside temperature / wet room temperature measuring transducers, calibratable, with multi-range switching and active output (Automatic Output Switching)



Dimensional drawing [mm]

ATM 2 - VA

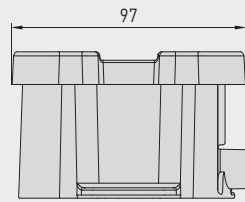
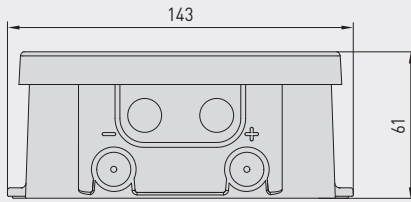

Housing with cable gland

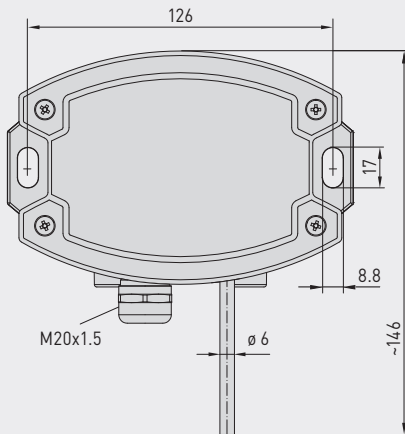

Housing with M12 connector

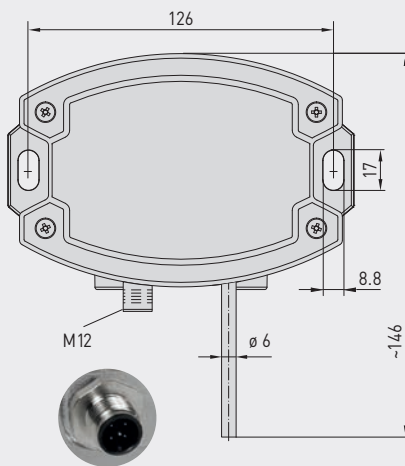

ATM 2 - VA with cable gland



ATM 2 - VAQ with M12 connector



High-performance encapsulation against vibration, mechanical stress and humidity

**PS-PROTECTION**  
PERFECT SENSOR PROTECTION

Automatic detection and switching to standard signal 0...10V or 4...20 mA

**AOS-PATENTED**  
AUTOMATIC OUTPUT SWITCHING

Outside temperature / wet room temperature measuring transducers, calibratable, with multi-range switching and active output (Automatic Output Switching)

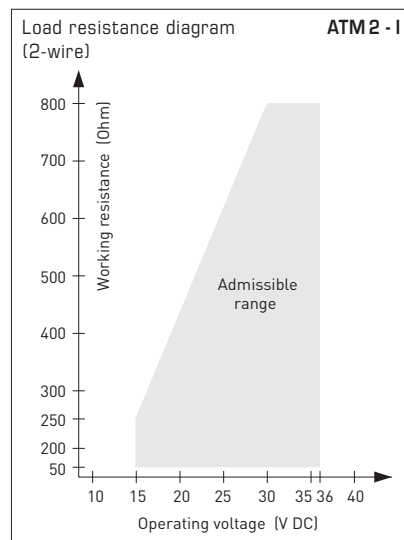
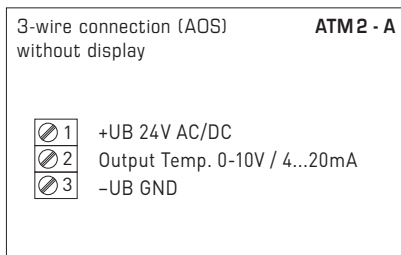
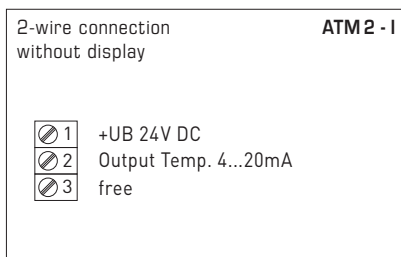
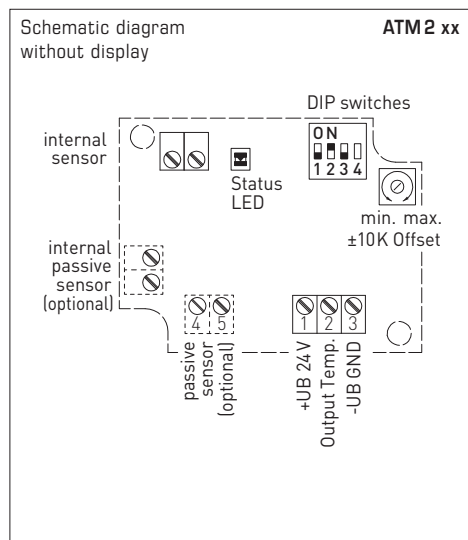

Measuring ranges [°C] (adjustable)	DIP 1	DIP 2	DIP 3
-20...+ 150 °C	ON	ON	ON
-50... + 50 °C	OFF	ON	ON
-20... + 80 °C	ON	OFF	ON
-30... + 60 °C	OFF	OFF	ON
0... + 40 °C	ON	ON	OFF
0... + 50 °C (default)	OFF	ON	OFF
0... + 100 °C	ON	OFF	OFF
0... + 150 °C	OFF	OFF	OFF

DIP4 has no function!

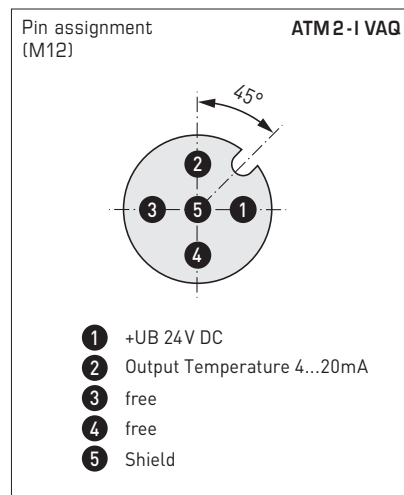
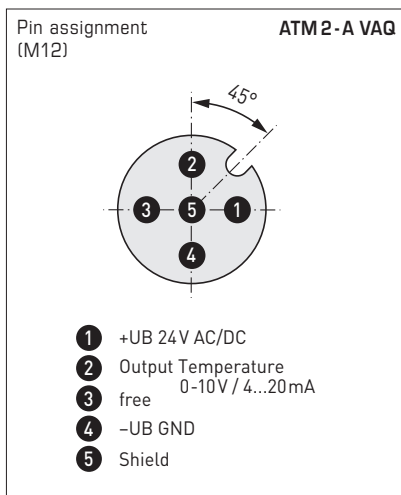

For further technical information, see the operating instructions

Accessories WS-01

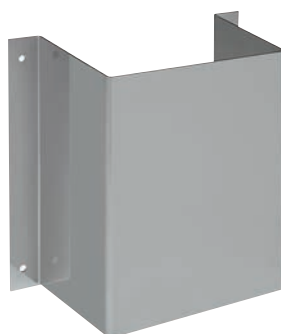

Accessories WS-03





NEW

S+S REGELTECHNIK

THERMASGARD® ATM 2 - VA

Outside temperature / wet room temperature measuring transducers, calibratable, with multi-range switching and active output (Automatic Output Switching)



ATM 2 - VAQ  
with M12 connector



ATM 2 - VA  
with cable gland

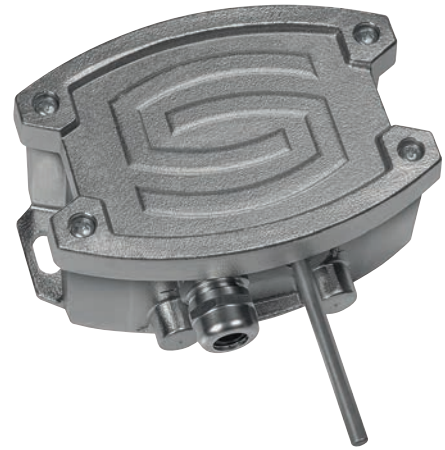

THERMASGARD® ATM 2 - VA		Outside temperature / wet room temperature measuring transducers, <i>ID</i> (Stainless steel housing with cable gland)	
Type / WG02I	Output	Item No.	Price
ATM 2 - I VA	(2-wire)		
ATM2-I VA	4...20 mA	2001-6171-2200-001	404,22 €
ATM 2 - A VA	(3-wire AOS)		
ATM2-A VA	0-10 V / 4...20 mA	2001-6171-B200-001	404,22 €
<b>Automatic Output Switching (AOS):</b>	Patented analogue interface (patent no. DE 10 2015 015 941 B4) Unit automatically detects the required output type 0-10 V or 4...20 mA.		
<b>Housing variant:</b>	Cable connection with cable gland		
<b>Extra charge:</b>	other measuring ranges optional		27,21 €

THERMASGARD® ATM 2 - VAQ		Outside temperature / wet room temperature measuring transducers, <i>ID</i> (Stainless steel housing with M12 connector)	
Type / WG02I	Output	● = Q Item No.	Price
ATM 2 - I VAQ	(2-wire)		
ATM2-I VAQ	4...20 mA	● 2001-6171-2100-001	445,49 €
ATM 2 - A VAQ	(3-wire AOS)		
ATM2-A VAQ	0-10 V / 4...20 mA	● 2001-6171-B100-001	445,49 €
<b>Automatic Output Switching (AOS):</b>	Patented analogue interface (patent no. DE 10 2015 015 941 B4) Unit automatically detects the required output type 0-10 V or 4...20 mA.		
<b>Housing variant "Q":</b>	Cable connection with M12 connector (male, 5-pin, A-code)		
<b>Extra charge:</b>	other measuring ranges optional		27,21 €

ACCESSORIES			
WS-01	Sun and ball-impact protection hood, 184 x 180 x 80 mm, stainless steel V2A (1.4301)	7100-0040-2000-000	34,03 €
WS-03	Weather and sun protection hood, 200 x 180 x 150 mm, stainless steel V2A (1.4301)	7100-0040-6000-000	47,92 €
<b>Special accessories for M12 connector</b> see chapter Accessories!			